

Genel Amaçlı Zamanlayıcılar

General Purpose Timers:

- TIM2-TIM5 ve TIM9-TIM14 genel amaçlı timerlardır.
- 16-bit (TIM3,TIM4) or 32-bit (TIM2,TIM5) yukarı, aşağı, yukarı/aşağı otomatik yeniden yüklenen sayıcılar.
- Prescaler ile frekans 1-65536 sayısına bölünebilir.
- 4' kadar bağımsız kanal her kanaldan
 - Giriş yakalama
 - Çıkış karşılaştırma
 - Tek darbe modu çıkış
 - PWM

Genel Amaçlı Zamanlayıcılar

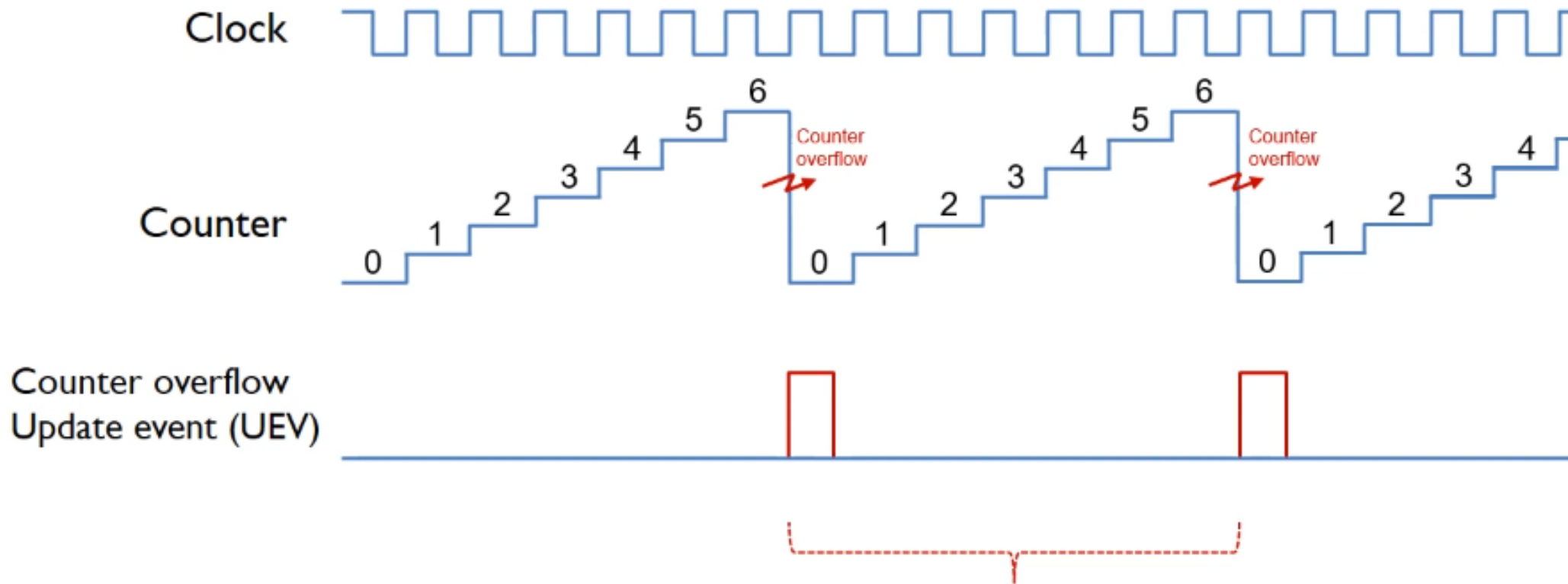

$$\begin{aligned} \text{Period} &= (1 + \text{ARR}) * \text{Clock Period} \\ &= 7 * \text{Clock Period} \end{aligned}$$

Kaynak: <https://www.youtube.com/watch?v=zkrVHicLGww>

Genel Amaçlı Zamanlayıcılar

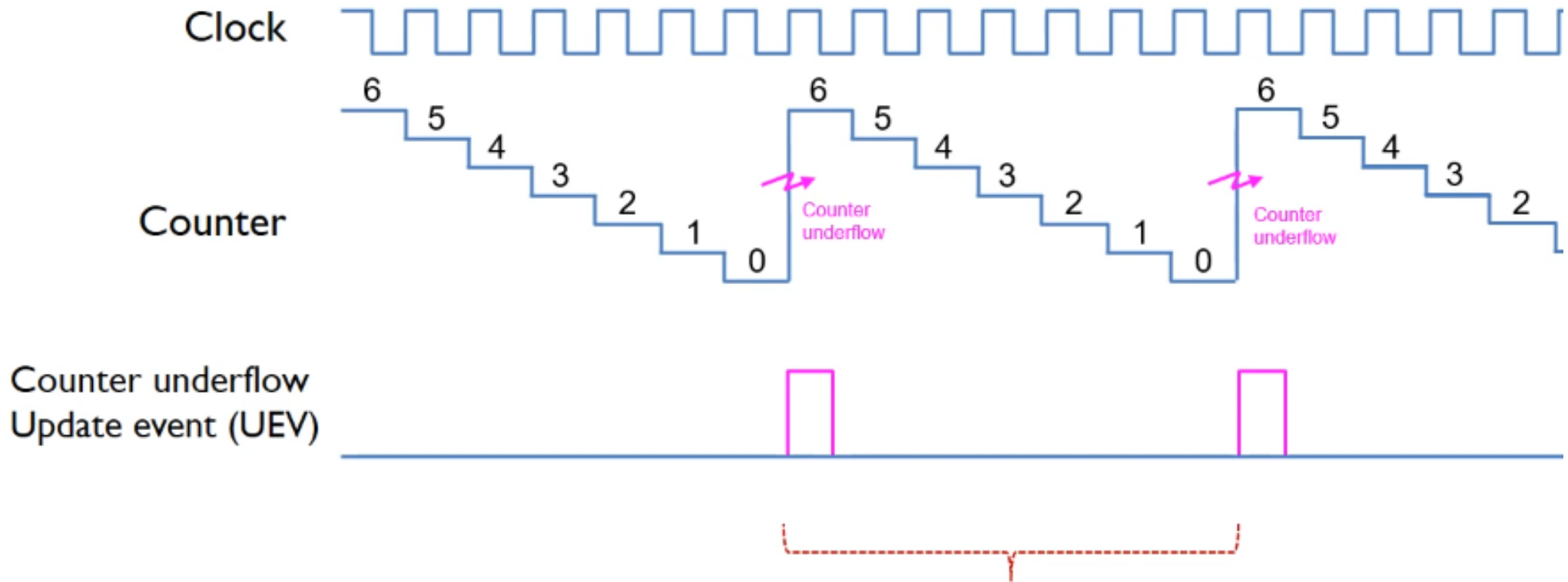

$$\begin{aligned} \text{Period} &= (1 + \text{ARR}) * \text{Clock Period} \\ &= 7 * \text{Clock Period} \end{aligned}$$

Genel Amaçlı Zamanlayıcılar

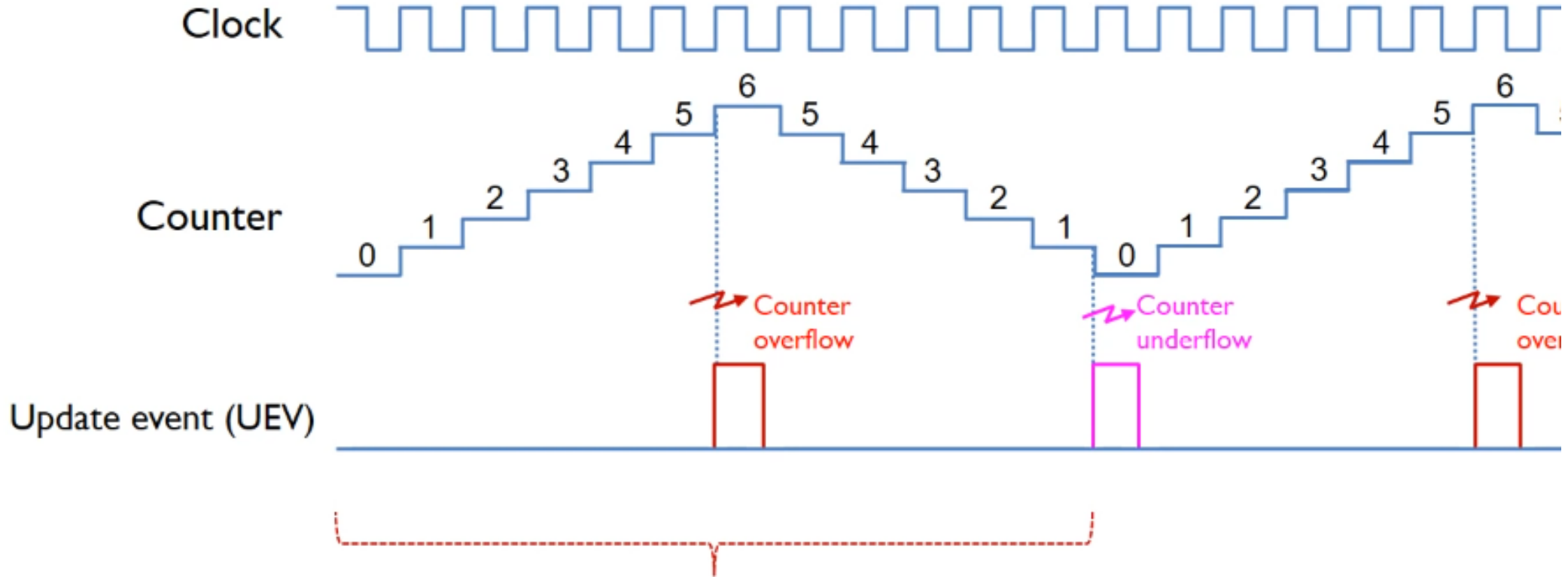

$$\begin{aligned} \text{Period} &= 2 * \text{ARR} * \text{Clock Period} \\ &= 12 * \text{Clock Period} \end{aligned}$$

Genel Amaçlı Zamanlayıcılar

Giriş yakalama (input sinyalinin frekansını ölçme)

- Bunun için input sinyalinin örneğin yükselen kenarı filtre ve kenar tespit ünitesi ile tespit edilir. Bu tespit anında timer sayacındaki sayı CCR yazmacına donanım tarafından yazılır.
 - Kenar tespit edildiğinde kesme tetiklenir, CCR'nin değeri bir değişkende saklanır.
 - İkinci defa aynı kenar (yükselen kenar) tespit edilir ve yine CCR yazmacına donanım tarafından yazılır.
 - Bir önceki saklanan değerden bu değer çıkarılarak gelen sinyalin iki kenarı arasındaki zamanlayıcının ne kadar saydığı bulunur.
 - Mikrodenetleyicinin çalışma frekansına göre input sinyalinin periyodu dolayısıyla frekansı tespit edilir. 5/25
-

Genel Amaçlı Zamanlayıcılar

Çıkış karşılaştırma (outputta kare dalga oluşturma)

- Zamanlayıcının sayacı CCR yazmacında belirlenmiş bir değere ulaştığında outputta 1 var ise 0, 0 var ise 1 yapılır.

Tek darbe modu - One Pulse Mode

- Belirlenmiş bir süre outputta 1 sinyali oluşturulacak şekilde zamanlayıcı ayarlanabilir.
- Sayaç CCR değerine ulaştığında outputa 1 sinyali verilir,
- Sayaç ARR değerine ulaştığında output 0 yapılır ve sayacın CEN inputu donanım tarafından 0 yapılır.

PWM

Mode 1

Timer Output =

High if counter < CCR
Low if counter ≥ CCR

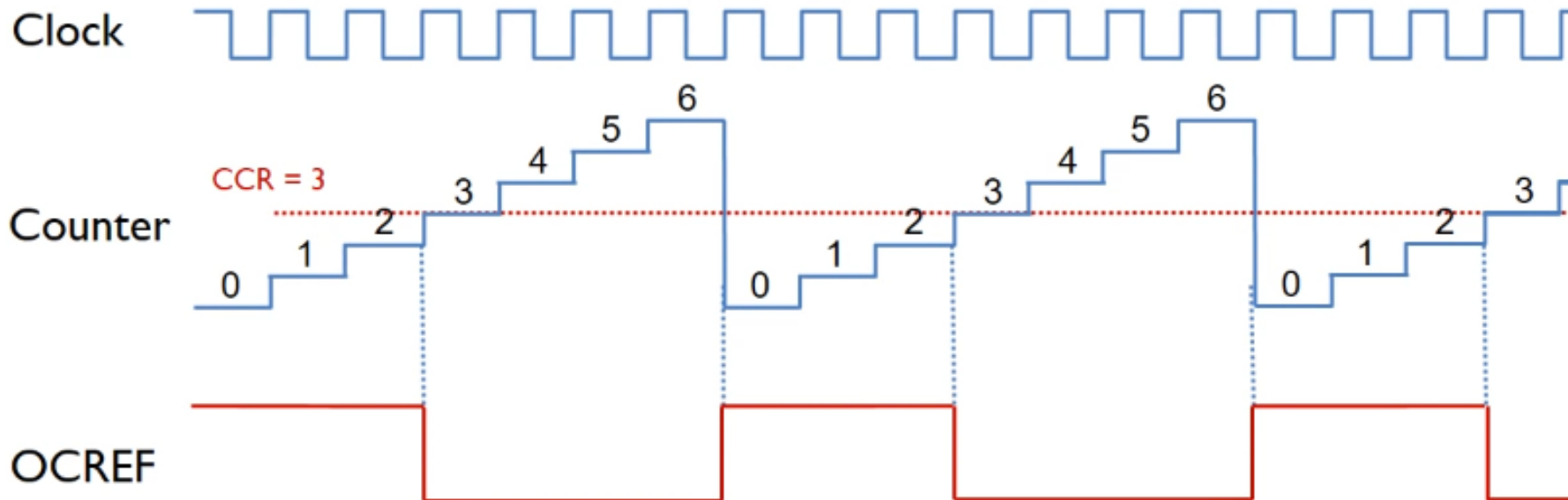

$$\begin{aligned} \text{Duty Cycle} &= \frac{\text{CCR}}{\text{ARR} + 1} \\ &= \frac{3}{7} \end{aligned}$$

$$\begin{aligned} \text{Period} &= (1 + \text{ARR}) * \text{Clock Period} \\ &= 7 * \text{Clock Period} \end{aligned}$$

PWM

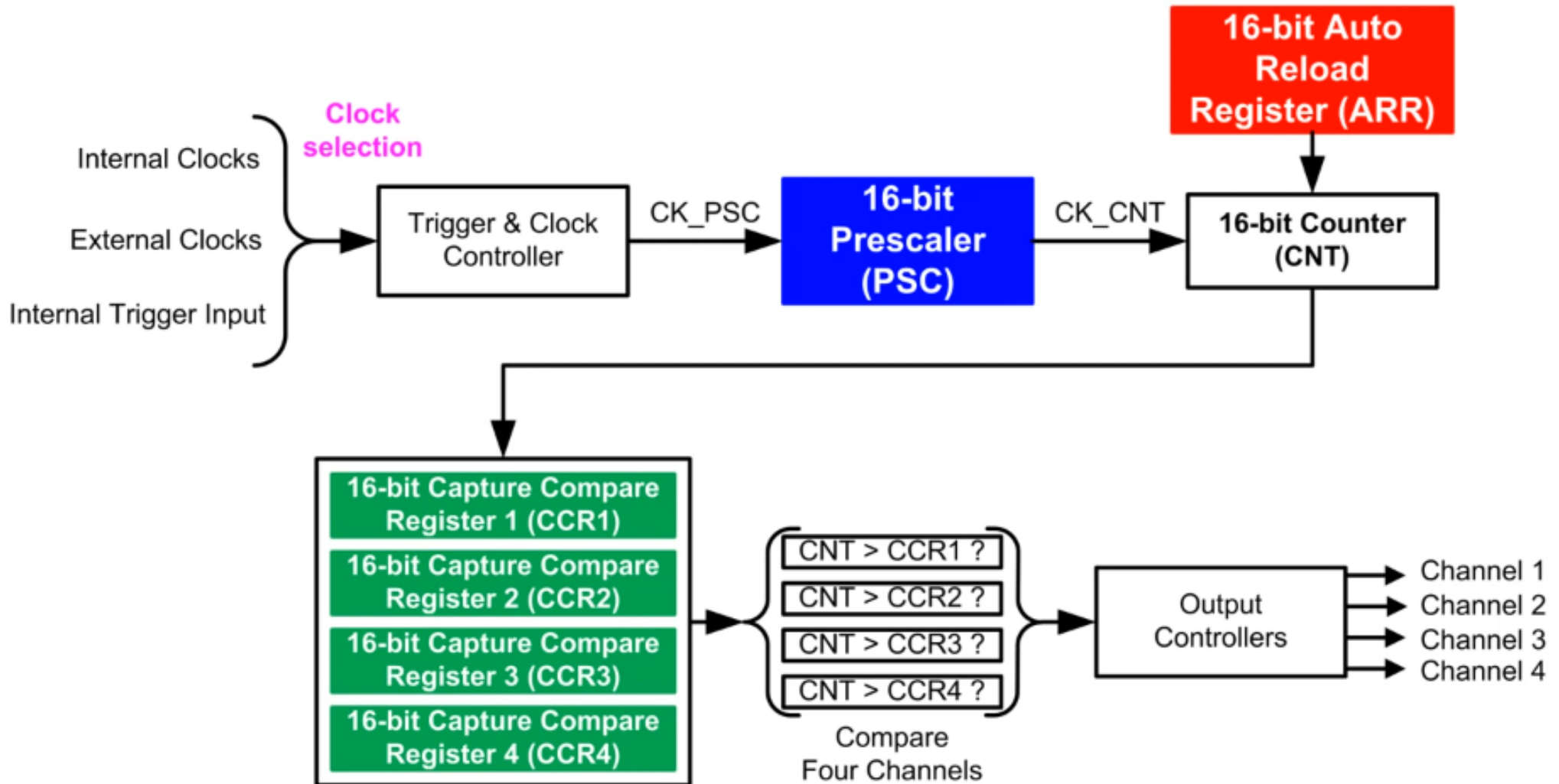

Genel Amaçlı Zamanlayıcılar

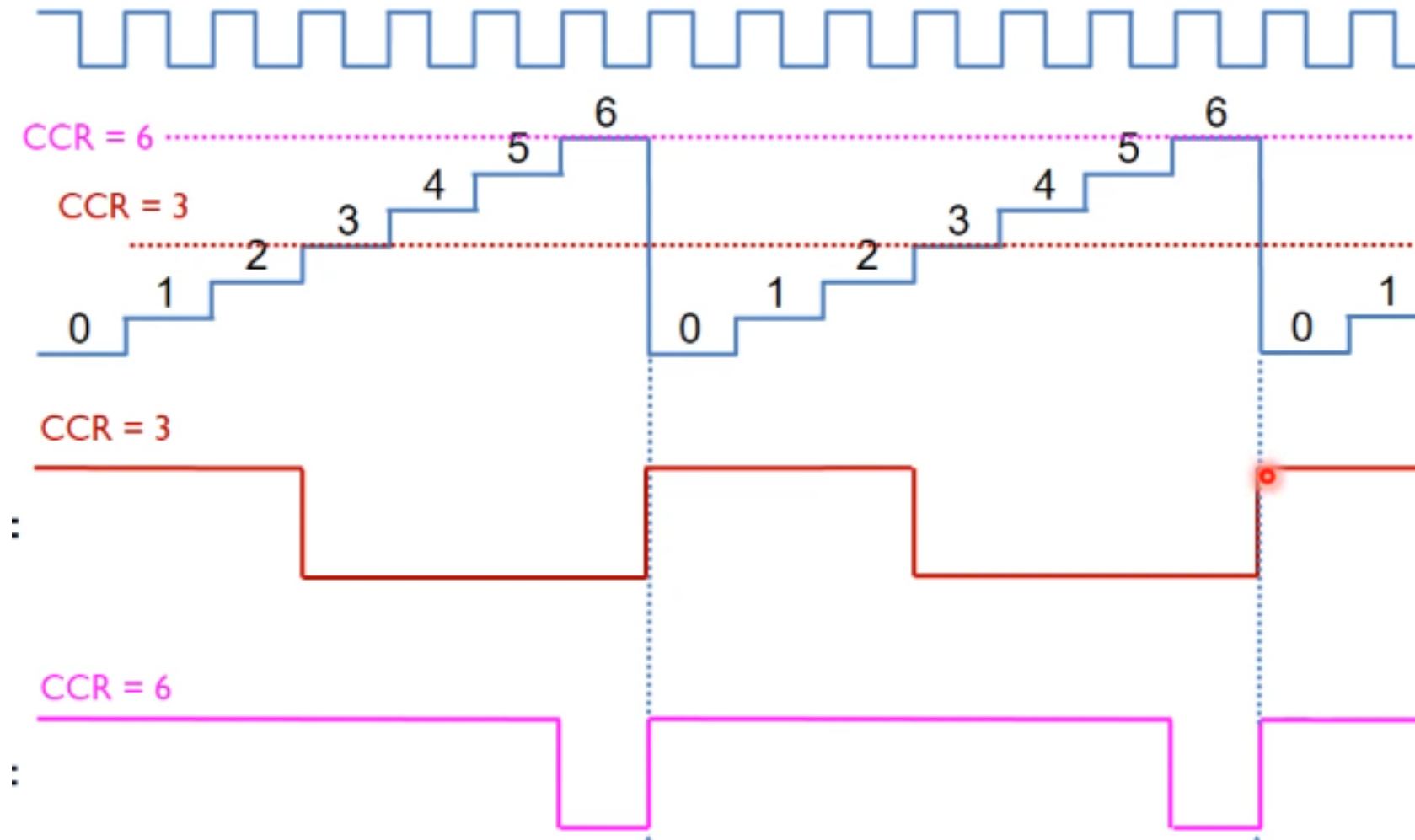

Genel Amaçlı Zamanlayıcılar

Mode 2

Timer Output =

Low if counter < CCR
High if counter ≥ CCR

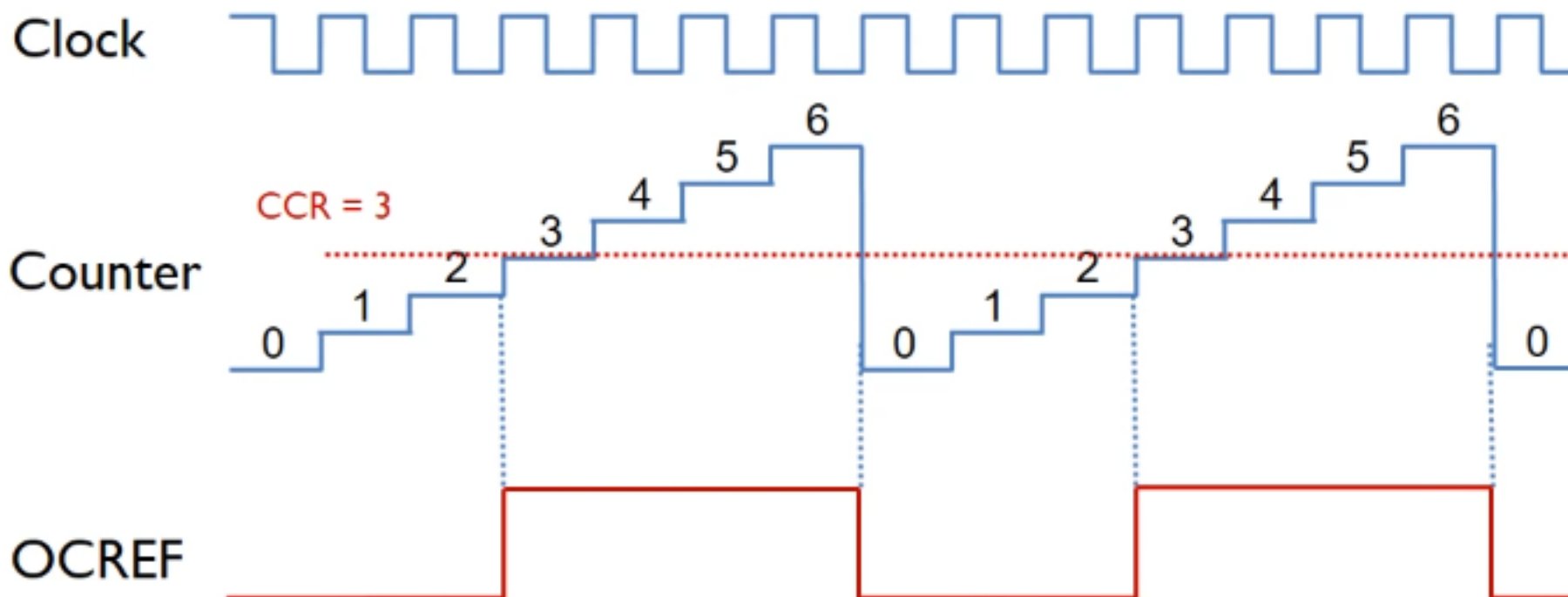

$$\begin{aligned} \text{Duty Cycle} &= 1 - \frac{\text{CCR}}{\text{ARR} + 1} \\ &= \frac{4}{7} \end{aligned}$$

$$\begin{aligned} \text{Period} &= (1 + \text{ARR}) * \text{Clock Period} \\ &= 7 * \text{Clock Period} \end{aligned}$$

Genel Amaçlı Zamanlayıcılar

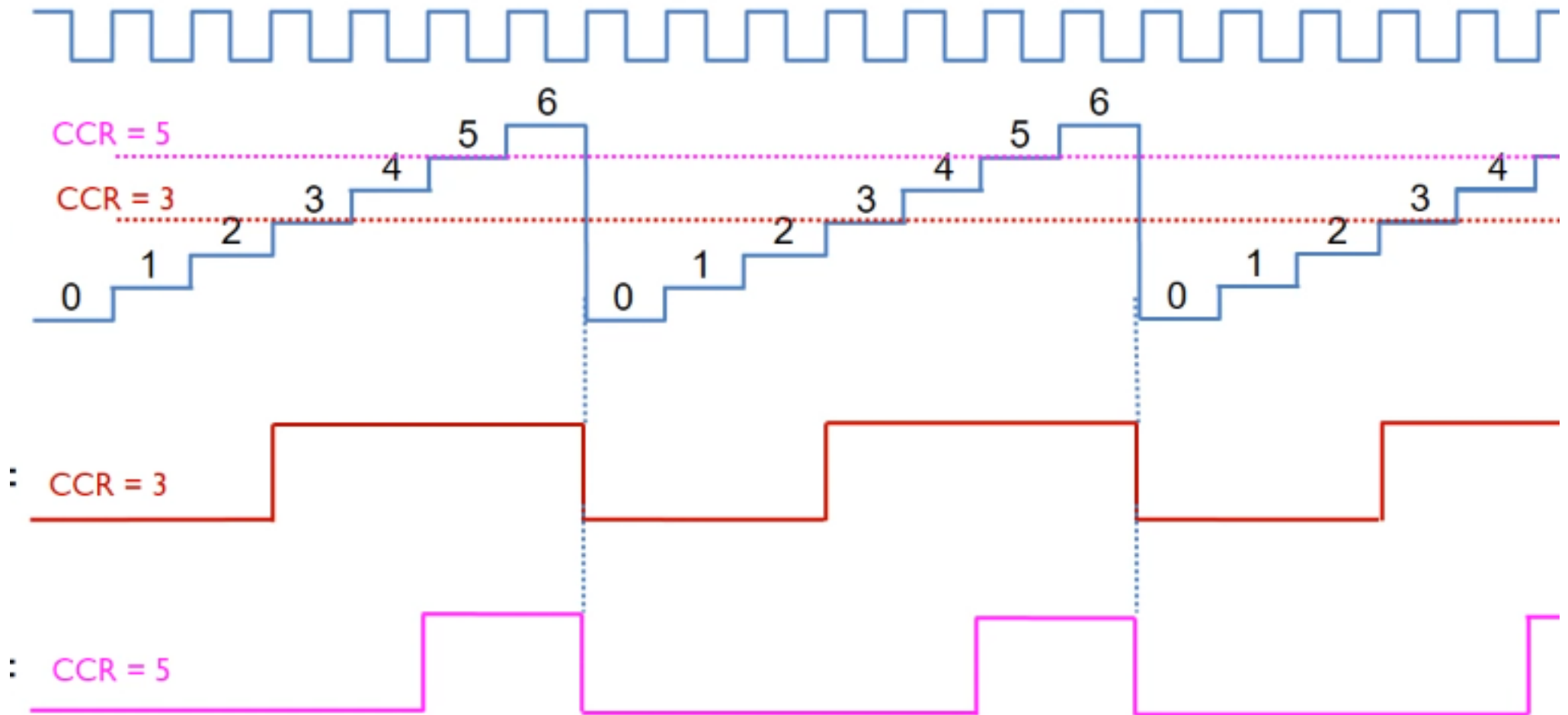

Genel Amaçlı Zamanlayıcılar

Mode 2

Timer Output =

Low if counter < CCR

High if counter ≥ CCR

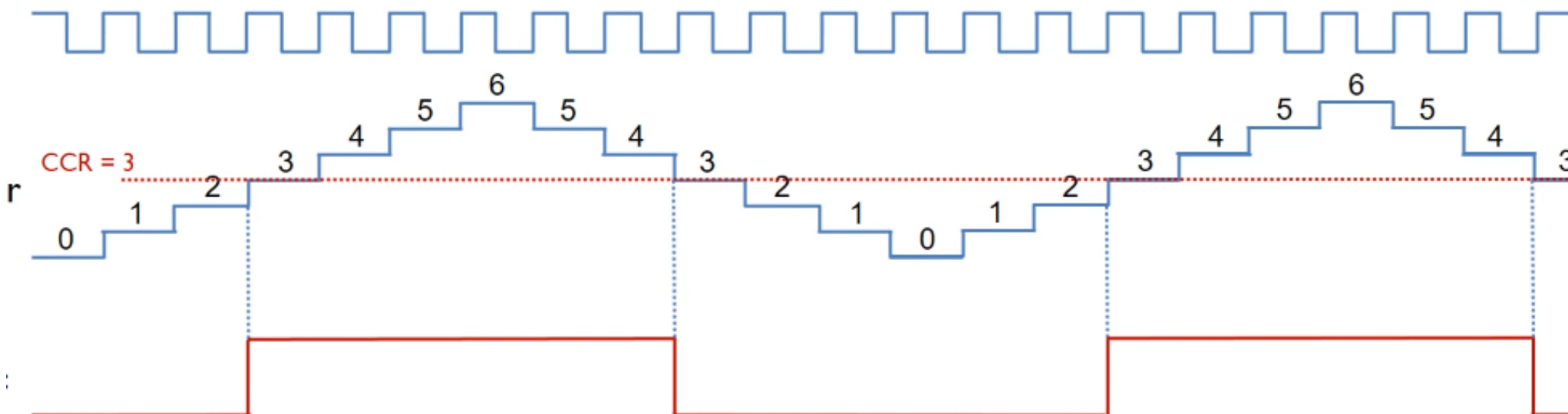

$$\text{Duty Cycle} = 1 - \frac{\text{CCR}}{\text{ARR}}$$
$$= \frac{1}{2}$$

$$\text{Period} = 2 * \text{ARR} * \text{Clock Period}$$
$$= 12 * \text{Clock Period}$$

Genel Amaçlı Zamanlayıcılar

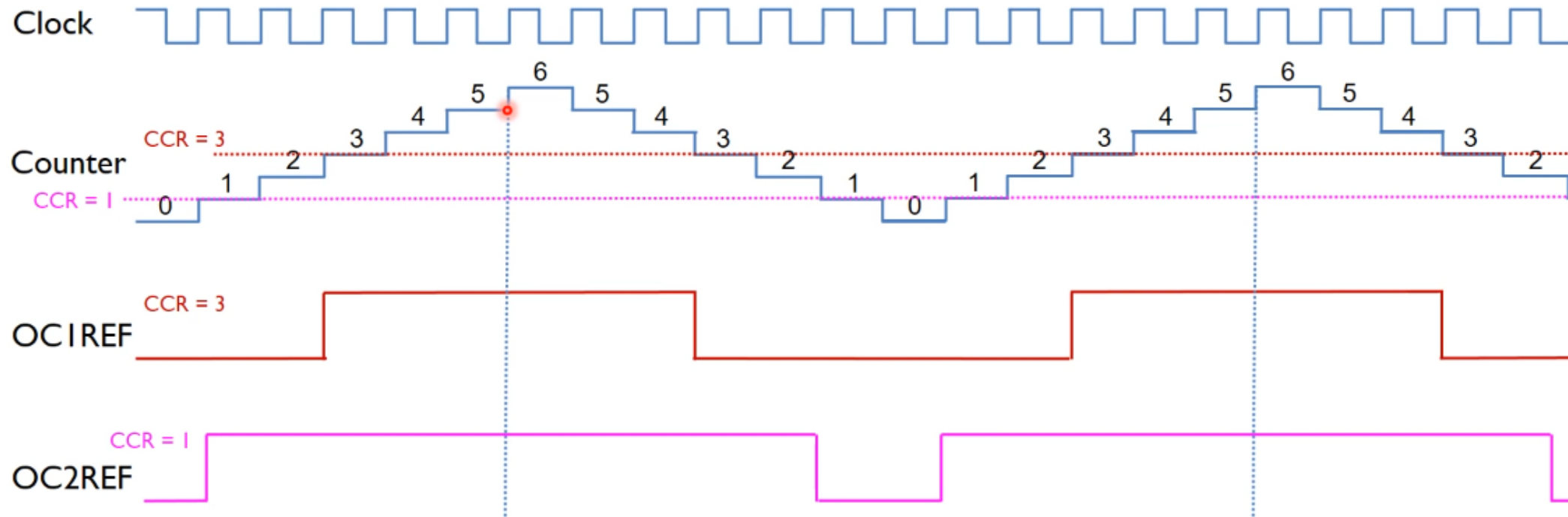

Genel Amaçlı Zamanlayıcılar

- STM32F407xx Datasheetinde (dm00037051) alternatif fonksiyonların hangi pinlerle kullanılabileceği gösterilen alternatif fonksiyon haritası bulunmaktadır.
- Örneğin TIM3 Kanal 1 için PA6, PB4, PC6, TIM3 Kanal 2 için PA7, PB5, PC7 kullanılabilir.
- Alternatif Fonksiyon haritasında ayrıca TIM3'ün 2 numaralı alternatif fonksiyon olduğu gösterilmektedir.
- Alternatif Fonksiyon Yazmacında (GPIO_AFRL) Alternatif Fonksiyon haritasında gösterilen alternatif fonksiyon numarası yazılmalıdır.
- Örneğin Timer 6 için Alternatif fonksiyon numarası 2'dir (AF2). Dolayısıyla yazmacın ilgili pinine 0010 yazılmalıdır.
- Kullanılacak pinin GPIO_MODER yazmacında modunun alternatif mod olarak ayarlanması gereklidir.

Genel Amaçlı Zamanlayıcılar

TIMx control register 1 (TIMx_CR1)

Address offset: 0x00

Reset value: 0x0000

15	14	13	12	11	10	9	8	7	6	5	4	3	2	1	0
Reserved						CKD[1:0]		ARPE	CMS		DIR	OPM	URS	UDIS	CEN
						rw	rw	rw	rw	rw	rw	rw	rw	rw	rw

Bit 7 **ARPE**: Auto-reload preload enable

0: TIMx_ARR register is not buffered

1: TIMx_ARR register is buffered

Bit 0 **CEN**: Counter enable

0: Counter disabled

1: Counter enabled

Note: External clock, gated mode and encoder mode can work only if the CEN bit has been previously set by software. However trigger mode can set the CEN bit automatically by hardware.

CEN is cleared automatically in one-pulse mode, when an update event occurs.

Genel Amaçlı Zamanlayıcılar

Bits 6:5 **CMS**: Center-aligned mode selection

00: Edge-aligned mode. The counter counts up or down depending on the direction bit (DIR).

01: Center-aligned mode 1. The counter counts up and down alternatively. Output compare interrupt flags of channels configured in output (CCxS=00 in TIMx_CCMRx register) are set only when the counter is counting down.

10: Center-aligned mode 2. The counter counts up and down alternatively. Output compare interrupt flags of channels configured in output (CCxS=00 in TIMx_CCMRx register) are set only when the counter is counting up.

11: Center-aligned mode 3. The counter counts up and down alternatively. Output compare interrupt flags of channels configured in output (CCxS=00 in TIMx_CCMRx register) are set both when the counter is counting up or down.

Note: It is not allowed to switch from edge-aligned mode to center-aligned mode as long as the counter is enabled (CEN=1)

Bit 4 **DIR**: Direction

0: Counter used as upcounter

1: Counter used as downcounter

Note: This bit is read only when the timer is configured in Center-aligned mode or Encoder mode.

Genel Amaçlı Zamanlayıcılar

TIMx DMA/Interrupt enable register (TIMx_DIER)

Address offset: 0x0C

Reset value: 0x0000

15	14	13	12	11	10	9	8	7	6	5	4	3	2	1	0
Res.	TDE	Res	CC4DE	CC3DE	CC2DE	CC1DE	UDE	Res.	TIE	Res	CC4IE	CC3IE	CC2IE	CC1IE	UIE
	rw		rw	rw	rw	rw	rw		rw		rw	rw	rw	rw	rw

Bit 3 **CC3IE**: Capture/Compare 3 interrupt enable

0: CC3 interrupt disabled

1: CC3 interrupt enabled

Bit 2 **CC2IE**: Capture/Compare 2 interrupt enable

0: CC2 interrupt disabled

1: CC2 interrupt enabled

Bit 1 **CC1IE**: Capture/Compare 1 interrupt enable

0: CC1 interrupt disabled

1: CC1 interrupt enabled

Bit 0 **UIE**: Update interrupt enable

0: Update interrupt disabled

1: Update interrupt enabled

Genel Amaçlı Zamanlayıcılar

TIMx status register (TIMx_SR)

Address offset: 0x10

Reset value: 0x0000

15	14	13	12	11	10	9	8	7	6	5	4	3	2	1	0		
Reserved				CC4OF	CC3OF	CC2OF	CC1OF	Reserved			TIF	Res	CC4IF	CC3IF	CC2IF	CC1IF	UIF
				rc_w0	rc_w0	rc_w0	rc_w0				rc_w0		rc_w0	rc_w0	rc_w0	rc_w0	rc_w0

Bit 0 **UIF**: Update interrupt flag

- ” This bit is set by hardware on an update event. It is cleared by software.
0: No update occurred.
1: Update interrupt pending. This bit is set by hardware when the registers are updated:
- ” At overflow or underflow (for TIM2 to TIM5) and if UDIS=0 in the TIMx_CR1 register.
- ” When CNT is reinitialized by software using the UG bit in TIMx_EGR register, if URS=0 and UDIS=0 in the TIMx_CR1 register.

When CNT is reinitialized by a trigger event (refer to the synchro control register description), if URS=0 and UDIS=0 in the TIMx_CR1 register.

Genel Amaçlı Zamanlayıcılar

Bit 3 **CC3IF**: Capture/Compare 3 interrupt flag
refer to CC1IF description

Bit 2 **CC2IF**: Capture/Compare 2 interrupt flag
refer to CC1IF description

Bit 1 **CC1IF**: Capture/compare 1 interrupt flag

If channel CC1 is configured as output:

This flag is set by hardware when the counter matches the compare value, with some exception in center-aligned mode (refer to the CMS bits in the TIMx_CR1 register description). It is cleared by software.

0: No match

1: The content of the counter TIMx_CNT matches the content of the TIMx_CCR1 register. When the contents of TIMx_CCR1 are greater than the contents of TIMx_ARR, the CC1IF bit goes high on the counter overflow (in upcounting and up/down-counting modes) or underflow (in downcounting mode)

If channel CC1 is configured as input:

This bit is set by hardware on a capture. It is cleared by software or by reading the TIMx_CCR1 register.

0: No input capture occurred

1: The counter value has been captured in TIMx_CCR1 register (An edge has been detected on IC1 which matches the selected polarity)

Genel Amaçlı Zamanlayıcılar

TIMx capture/compare mode register 1 (TIMx_CCMR1)

Address offset: 0x18

Reset value: 0x0000

15	14	13	12	11	10	9	8	7	6	5	4	3	2	1	0
OC2CE	OC2M[2:0]			OC2PE	OC2FE	CC2S[1:0]		OC1CE	OC1M[2:0]			OC1PE	OC1FE	CC1S[1:0]	
IC2F[3:0]				IC2PSC[1:0]				IC1F[3:0]				IC1PSC[1:0]			
rw	rw	rw	rw	rw	rw	rw	rw	rw	rw	rw	rw	rw	rw	rw	rw

Bits 6:4 **OC1M**: Output compare 1 mode

110: PWM mode 1 - In upcounting, channel 1 is active as long as $TIMx_CNT < TIMx_CCR1$ else inactive. In downcounting, channel 1 is inactive ($OC1REF = 0$) as long as $TIMx_CNT > TIMx_CCR1$ else active ($OC1REF = 1$).

111: PWM mode 2 - In upcounting, channel 1 is inactive as long as $TIMx_CNT < TIMx_CCR1$ else active. In downcounting, channel 1 is active as long as $TIMx_CNT > TIMx_CCR1$ else inactive.

Note: In PWM mode 1 or 2, the OCREF level changes only when the result of the comparison changes or when the output compare mode switches from “frozen” mode to “PWM” mode.

Genel Amaçlı Zamanlayıcılar

TIMx capture/compare enable register (TIMx_CCER)

Address offset: 0x20

Reset value: 0x0000

15	14	13	12	11	10	9	8	7	6	5	4	3	2	1	0
CC4NP	Res.	CC4P	CC4E	CC3NP	Res.	CC3P	CC3E	CC2NP	Res.	CC2P	CC2E	CC1NP	Res.	CC1P	CC1E
rw		rw	rw	rw		rw	rw	rw		rw	rw	rw		rw	rw

Bit 0 CC1E: *Capture/Compare 1 output enable.*

CC1 channel configured as output:

0: Off - OC1 is not active

1: On - OC1 signal is output on the corresponding output pin

CC1 channel configured as input:

This bit determines if a capture of the counter value can actually be done into the input capture/compare register 1 (TIMx_CCR1) or not.

0: Capture disabled

1: Capture enabled

Genel Amaçlı Zamanlayıcılar

TIMx counter (TIMx_CNT)

Address offset: 0x24

Reset value: 0x0000 0000

31	30	29	28	27	26	25	24	23	22	21	20	19	18	17	16
CNT[31:16] (depending on timers)															
rw	rw	rw	rw	rw	rw	rw	rw	rw	rw	rw	rw	rw	rw	rw	rw
15	14	13	12	11	10	9	8	7	6	5	4	3	2	1	0
CNT[15:0]															
rw	rw	rw	rw	rw	rw	rw	rw	rw	rw	rw	rw	rw	rw	rw	rw

Bits 31:16 **CNT[31:16]**: *High counter value (on TIM2 and TIM5).*

Bits 15:0 **CNT[15:0]**: Counter value

Genel Amaçlı Zamanlayıcılar

TIMx prescaler (TIMx_PSC)

Address offset: 0x28

Reset value: 0x0000

15	14	13	12	11	10	9	8	7	6	5	4	3	2	1	0
PSC[15:0]															
rw	rw	rw	rw	rw	rw	rw	rw	rw	rw	rw	rw	rw	rw	rw	rw

Bits 15:0 **PSC[15:0]**: Prescaler value

The counter clock frequency CK_CNT is equal to $f_{CK_PSC} / (PSC[15:0] + 1)$.

PSC contains the value to be loaded in the active prescaler register at each update event (including when the counter is cleared through UG bit of TIMx_EGR register or through trigger controller when configured in “reset mode”).

Genel Amaçlı Zamanlayıcılar

TIMx auto-reload register (TIMx_ARR)

Address offset: 0x2C

Reset value: 0xFFFF FFFF

31	30	29	28	27	26	25	24	23	22	21	20	19	18	17	16
ARR[31:16] (depending on timers)															
rw	rw	rw	rw	rw	rw	rw	rw	rw	rw	rw	rw	rw	rw	rw	rw
15	14	13	12	11	10	9	8	7	6	5	4	3	2	1	0
ARR[15:0]															
rw	rw	rw	rw	rw	rw	rw	rw	rw	rw	rw	rw	rw	rw	rw	rw

Bits 31:16 **ARR[31:16]**: High auto-reload value (on TIM2 and TIM5).

Bits 15:0 **ARR[15:0]**: Auto-reload value

Genel Amaçlı Zamanlayıcılar

TIMx capture/compare register 1 (TIMx_CCR1)

Address offset: 0x34

Reset value: 0x0000 0000

31	30	29	28	27	26	25	24	23	22	21	20	19	18	17	16
CCR1[31:16] (depending on timers)															
rw/ro	rw/ro	rw/ro	rw/ro	rw/ro	rw/ro	rw/ro	rw/ro	rw/ro	rw/ro	rw/ro	rw/ro	rw/ro	rw/ro	rw/ro	rw/ro
15	14	13	12	11	10	9	8	7	6	5	4	3	2	1	0
CCR1[15:0]															
rw/ro	rw/ro	rw/ro	rw/ro	rw/ro	rw/ro	rw/ro	rw/ro	rw/ro	rw/ro	rw/ro	rw/ro	rw/ro	rw/ro	rw/ro	rw/ro

Bits 31:16 **CCR1[31:16]**: High Capture/Compare 1 value (on TIM2 and TIM5).

Bits 15:0 **CCR1[15:0]**: Low Capture/Compare 1 value